

**1** TYP. 95'x145' LOT CONFIGURATION  
SCALE: 1" = 30'

**2** TYP. 85'x145' LOT CONFIGURATION  
SCALE: 1" = 30'

**3** TYP. 73'x135' LOT CONFIGURATION  
SCALE: 1" = 30'

VICINITY MAP

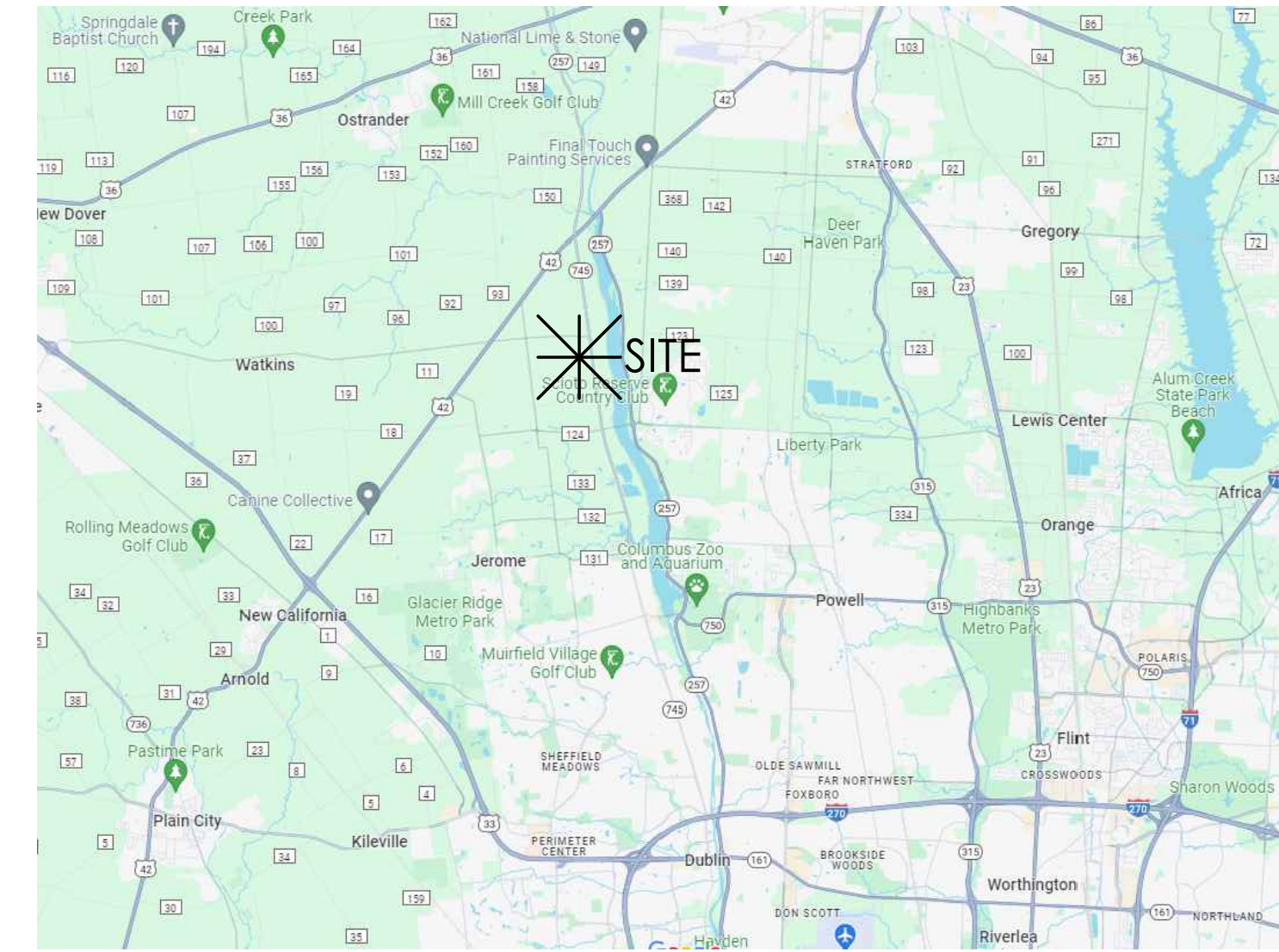

| SITE DATA                |                |
|--------------------------|----------------|
| TOTAL ACRES              | ±94.213 ACRES  |
| TOTAL UNITS              | 140 UNITS      |
| DENSITY                  | ±1.49 D.U./AC. |
| OPEN SPACE               | ±38.5 ACRES    |
| PERCENTAGE OF OPEN SPACE | ±40%           |

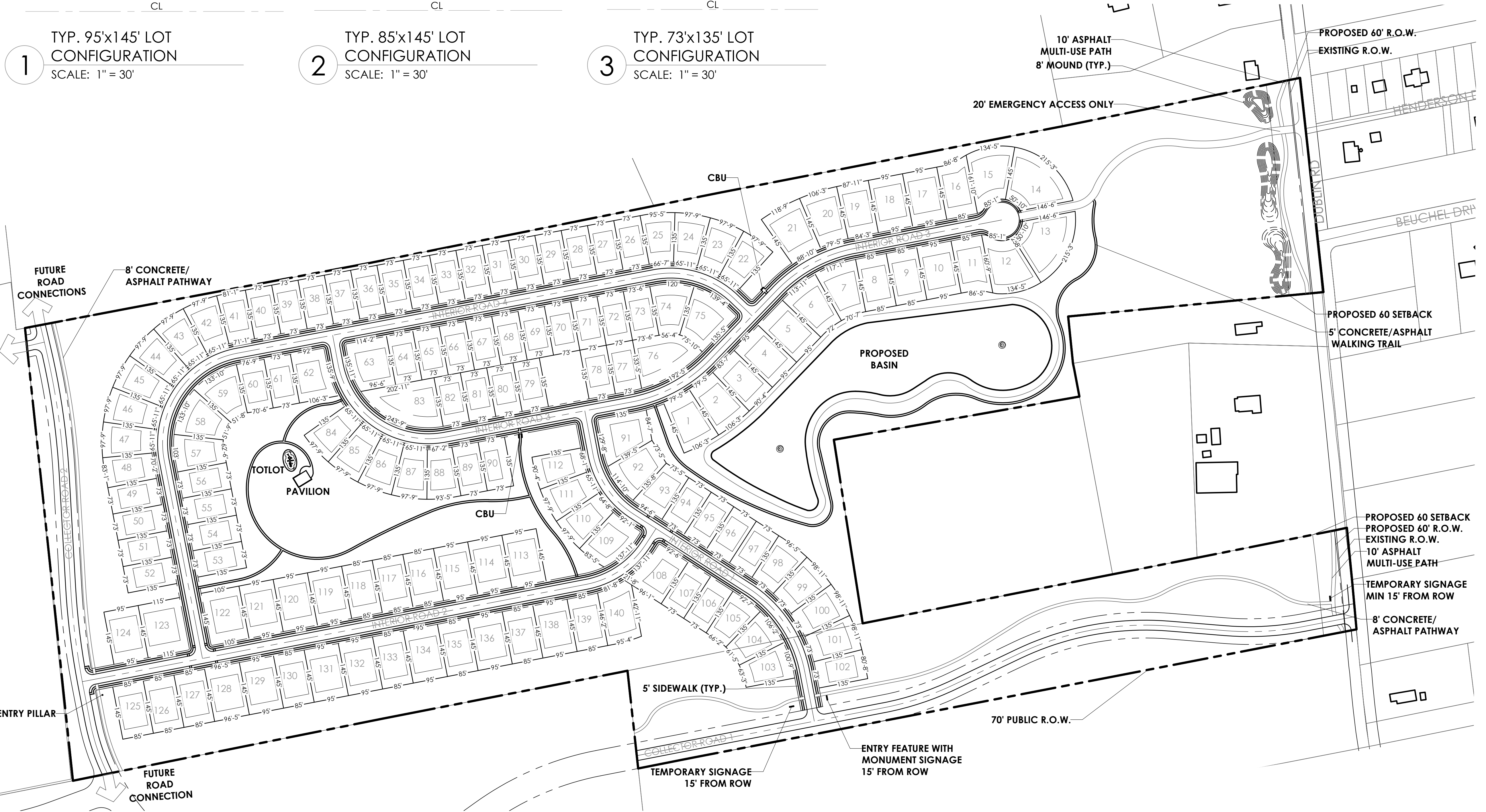

SITE DEVELOPMENT PLAN

EXHIBIT C-1

**HOLLYBROOK**  
PREPARED FOR KIRAN BASIREDDY  
DATE: 5.20.24

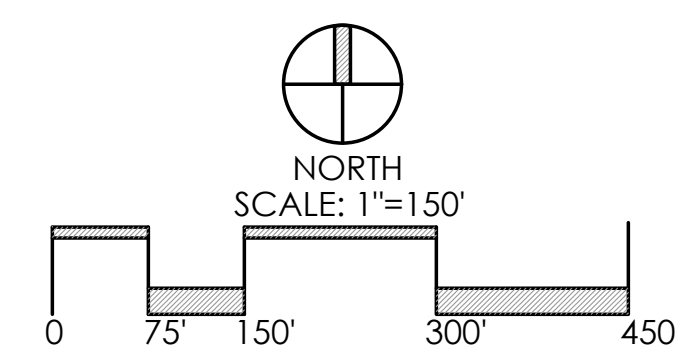

**Faris Planning & Design**  
LAND PLANNING      LANDSCAPE ARCHITECTURE  
4876 Cemetery Road      Hilliard, OH 43026  
p. (614) 487-1964      www.farisplanninganddesign.com