

### PLANT LIST - STREET TREES

(CONTRACTOR RESPONSIBLE FOR ALL PLANTS SHOWN ON PLAN)

QTY	KEY	BOTANICAL NAME	COMMON NAME	SIZE	COND.	REMARKS
DECIDUOUS TREES						
22	ACS2	ACER SACCHARUM	SUGAR MAPLE	2.5" CAL.	B&B	
15	GYE2	GYMNOCLADUS DIOICUS 'ESPRESSO-JFS'	ESPRESSO KENTUCKY COFFEE TREE	2.5" CAL.	B&B	
30	LIR2	LIRODENDRON TULIPIFERA	TULIP TREE	2.5" CAL.	B&B	
31	NYS2	NYSSA SYLVATICA	BLACKGUM	2.5" CAL.	B&B	
44	PLA2	PLATANUS X ACERIFOLIA 'BLOODGOOD'	BLOODGOOD LONDON PLANETREE	2.5" CAL.	B&B	
32	TIA2	TILIA AMERICANA 'REDMOND'	REDMOND AMERICAN LINDEN	2.5" CAL.	B&B	ADS, POS
55	ULM2	ULMUS AMERICANA 'PRINCETON'	PRINCETON AMERICAN ELM	2.5" CAL	B&B	

\* NOTE: ALL STREET TREES TO BE PLANTED ONE (1) FOOT MINIMUM BEHIND ROADWAY RIGHT OF WAY.

### PLANT KEY TYPICALS

SEE PLANT LIST FOR SPECIFIC PLANT SPECIES

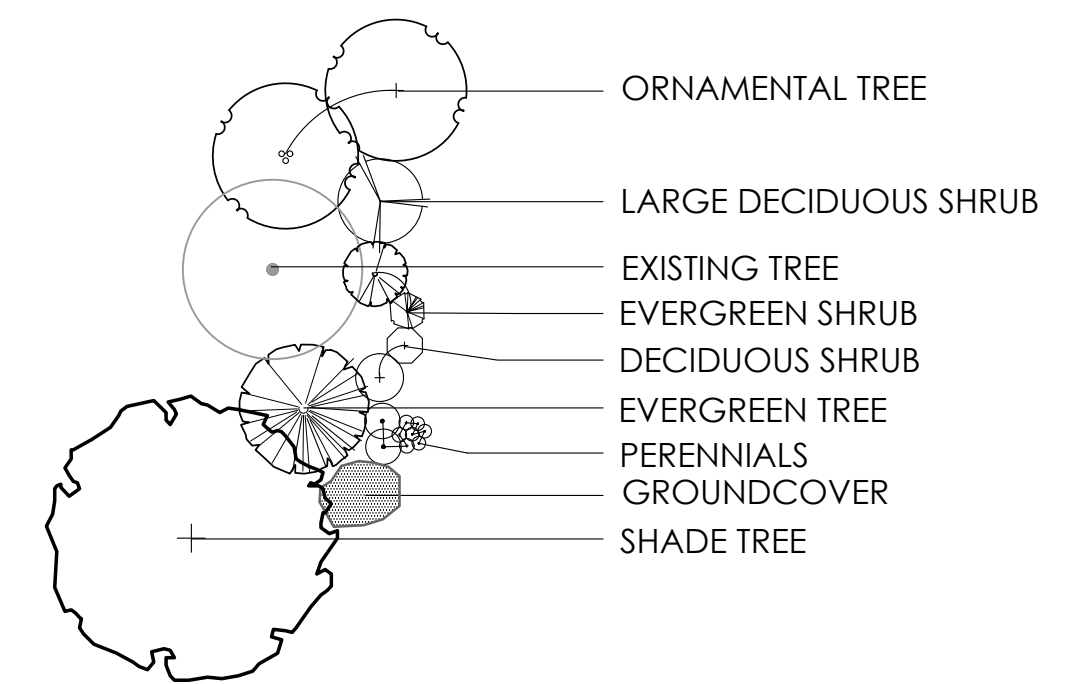

# OVERALL LANDSCAPE AND STREET TREE PLAN-WEST

# EXHIBIT D-2

# HOLLYBROOK

PREPARED FOR KIRAN BASIREDDY  
DATE: 5.20.24

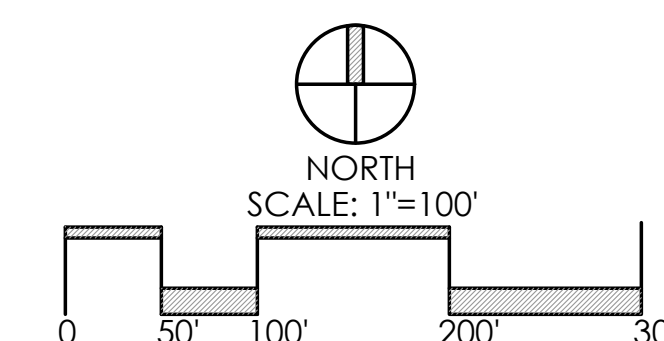

## Faris Planning & Design

LAND PLANNING LANDSCAPE ARCHITECTURE  
4876 Cemetery Road Hilliard, OH 43026  
p. (614) 487-1964 www.farisplanninganddesign.com